

SOTIC RIFLE USER MANUAL

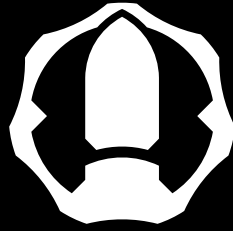

KRG

KRG-OPS.com

1. RULES OF FIREARM SAFETY

1.1 ALWAYS Keep The Gun Pointed In A Safe Direction

This is the primary rule of gun safety. Common sense dictates the safest direction, depending on different circumstances.

1.2 ALWAYS Keep Your Finger Off The Trigger Until Ready To Shoot

When holding a gun, rest your finger alongside the frame and outside the trigger guard. Until you are actually ready to fire, do not touch the trigger.

1.3 ALWAYS Keep The Gun Unloaded Until Ready To Use

If you do not know how to open the action or inspect the chamber(s), leave the gun alone and get help from someone who does.

2. SOTIC RIFLE CONFIGURATIONS

2.1 Calibers

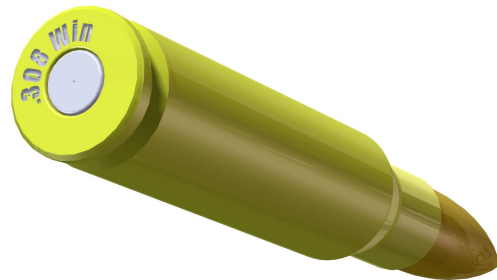

How to read the caliber:

The information on the chambering of the rifle is on the barrel toward the breech end.

The info is shown according to the picture:

1. Top line is the chambering, in this case the rifle is chambered for the .308 Winchester cartridge
2. The second line is the twist rate. In this case there is 1 rotation in 10", commonly called a "10 twist"
3. The third line refers to the actual chamber dimensions. Our chamber differs slightly from SAAMI spec for .308 Winchester.
4. The fourth line has two numbers, both in inches. The first number is the amount of free bore (FB) which in this case is .123". The second number is the theoretical distance from the bolt face to the lands (BFTL) of the bore with the above chamber spec. This is an approximate number and is given so that shooters can calculate how far off the lands the bullet sits in their favorite ammunition.

2.2 Rifle Features

	SOTIC Fixed		SOTIC Folder	
Caliber	.308	6.5 Creedmoor	.308	6.5 Creedmoor
Twist	1-10"	1-8"	1-10"	1-8"
Barrel Length	20"	22"	20"	22"
Overall Length	39.6" - 43.4"		30.2" - 43.4"	
Weight	9.38 - 9.68 lbs		9.63 - 9.93 lbs	

3. PARTS OF YOUR FIREARM



3.1 THE SAFETY

Selector Lever/Safety:

The safety mechanism in the SOTIC rifle blocks both the trigger and the firing pin and locks the bolt closed. It is engaged and the rifle is "on safe" when the lever is to the rear as shown. Pushing the lever forward disengages the safety and puts the rifle in the ready-to-fire condition. You should only have the rifle ready to fire with the safety off when you are prepared to shoot and have a good aim at your target.

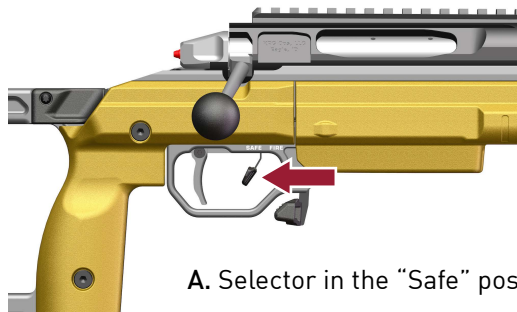

A. Selector in the "Safe" position

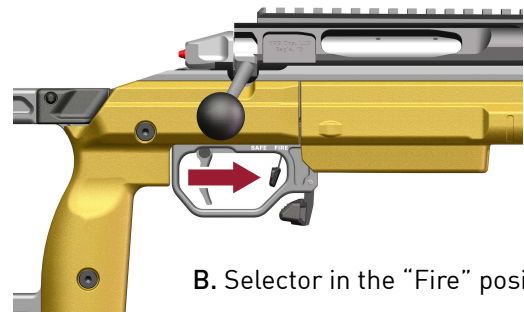

B. Selector in the "Fire" position

3.2 THE BOLT ASSEMBLY

A. Installing the bolt

1. Ensure the firearm is unloaded and pointed in a safe direction.
2. Line up the bolt lugs with the hole in the back of the receiver.
3. Slide the bolt forward until it stops.
4. Push down on the bolt handle locking the bolt assembly in the closed position.
5. Place the firearm on "Safe"



B. Removing the bolt

1. Make sure the firearm is unloaded and pointed in a safe direction.
2. Place the firearm on "Fire"
3. Lift the bolt handle.
4. Push and hold the bolt stop/release button on the left side of the receiver.
5. Pull the bolt to the back and remove it from the firearm.



C. Disassembly of the rifle bolt

The SOTIC bolt can be disassembled for cleaning with no tools but it does take a bit of care.

1. Ensure the firearm is unloaded and pointed in a safe direction.
2. Place the firing selector on "Fire" and remove the bolt.
3. Grab the bolt shroud very tightly and rotate it clockwise as if you were looking at it from the rear of the bolt. This is the direction away from the helical cocking cam.
4. When the bolt shroud hits the release point, the firing pin spring will push the shroud away from the bolt body, it is a strong spring so keep ahold of the bolt shroud.
5. Remove the firing pin spring, cocking indicator, and firing pin/cocking piece from the bolt.

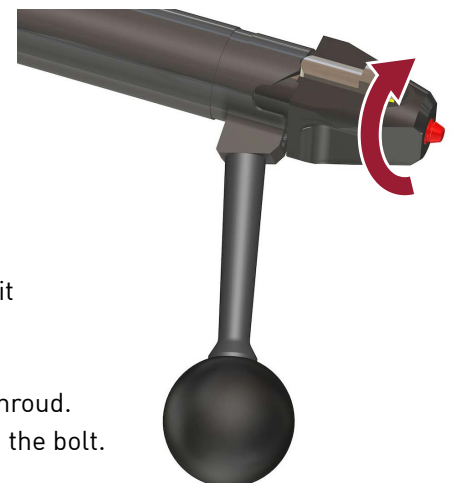

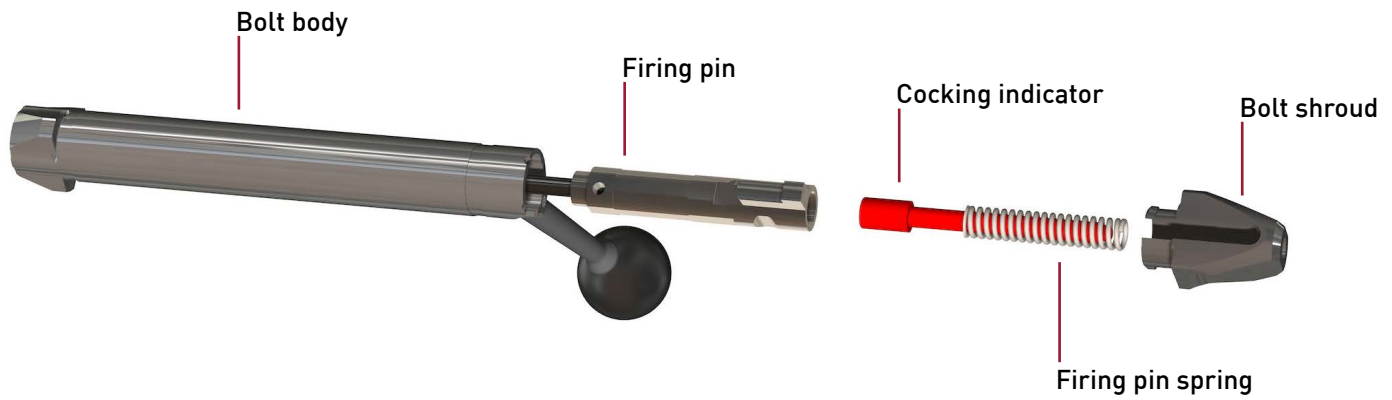

D. Firing Pin Spring Adjustment

The SOTIC rifle comes with the ability to increase or decrease the firing pin spring pressure based on the needs of the user. It uses a simple spacer system, and comes from KRG without any spacers installed to give the lightest bolt lift.

Two spacers are included in the packet of accessory items that come with the rifle. If you experience light primer strikes with your particular type of ammo, you may find it beneficial to add one or two spacers to the firing pin assembly as shown in order to strengthen the force of the firing pin. This is simply done by disassembling the bolt as shown elsewhere and adding the spacer (s) to the location shown in the image below.

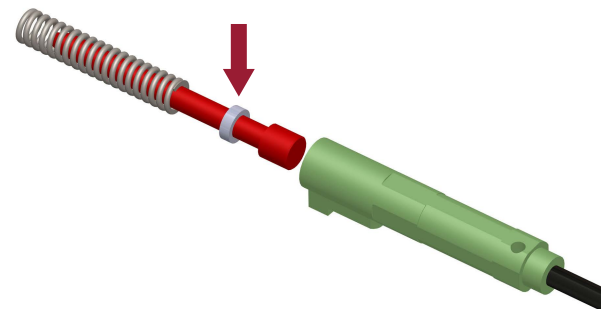

E. Re-assembly of the rifle bolt

Re-assembly of the bolt is done in the reverse of the disassembly, it is not easy to compress the firing pin spring so keep a good hold on the bolt shroud. Take into account the following particular considerations:

1. During re-assembly, make sure that the cocking piece/firing pin is aligned to the side of the red notch shown in the image (the side toward the helical cocking cam). The notch is not red on the actual bolt.
2. Make sure spring is seated into pocket in bolt shroud, then push in on the shroud to compress the spring until the locking lugs on the shroud enter the bolt body and stop against the bottom of the groove.
3. Turn the bolt shroud counterclockwise until the cocking piece engages its groove just on the edge of the helical cam.

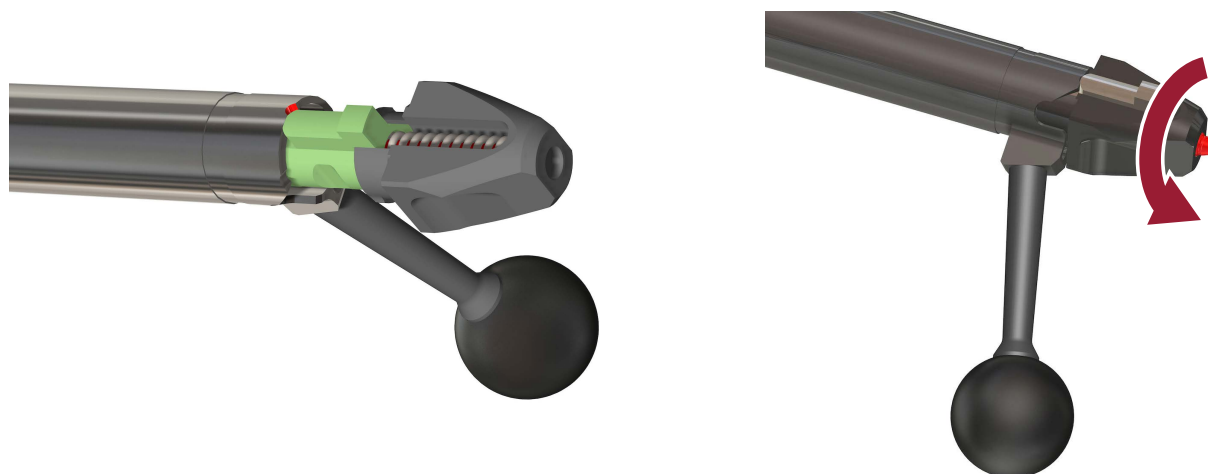

3.3 THE TRIGGER ASSEMBLY

Trigger Adjustments: *****Make sure rifle is unloaded before making any trigger adjustments*****

The trigger in the SOTIC rifle is a two-stage trigger with multiple adjustments. Some can be done by the end user and some require a certified gunsmith. Each of the end user adjustments can be done with the trigger still attached to the rifle. From left to right in the trigger graphic, here is how to make the adjustments:

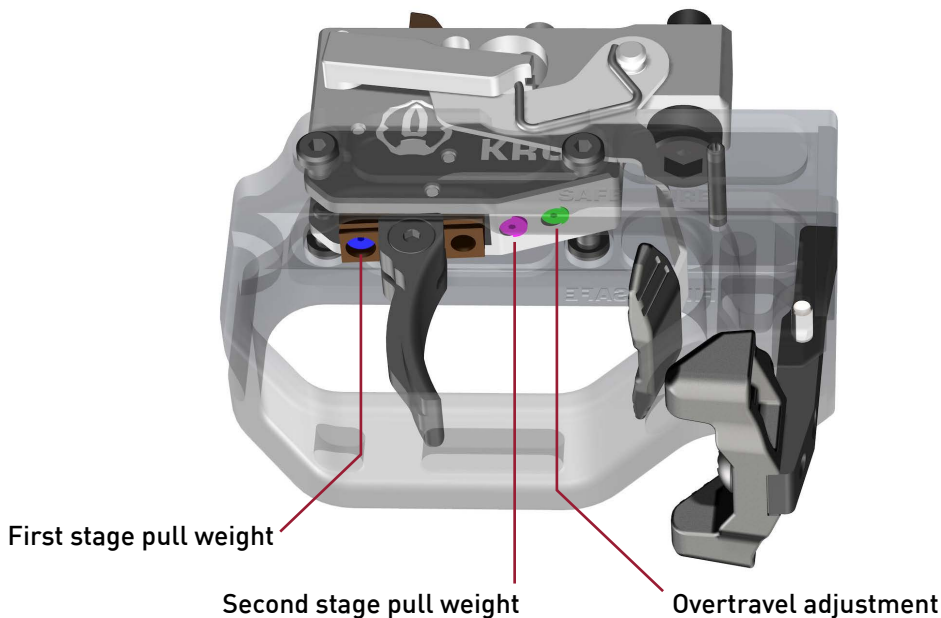

*****Do not set overall pull less than 2lb 8oz, dangerous condition could result*****

A. First stage pull weight (blue screw in image)

1. Insert 2mm hex wrench through trigger guard to turn the blue screw shown in the picture (not blue on the actual rifle). This screw might be covered by the trigger shoe. If so, loosen the flat head screw that locks the trigger shoe in place with a 2mm hex wrench and slide the trigger shoe forward.

2. Tighten the blue screw clockwise to increase the first stage pull weight. Loosen the screw to decrease first stage pull weight. If you tighten it too much, it will compress the spring to solid and the trigger will not function. If this happens, just loosen the screw. If you loosen the screw too much, the screw and spring will fall out.

B. Second stage pull weight (pink screw in image):

1. Insert 2mm hex wrench through trigger guard to turn the pink screw (not pink on the actual rifle).

2. Tighten the pink screw clockwise to increase the second stage pull weight. Loosen it to decrease second stage pull weight. If you tighten it too much, it will compress the spring to solid and the trigger will not function. If this happens, just loosen the screw. If you loosen the screw too much, the screw and spring will fall out.

C. Overtravel adjustment (green screw in image)

1. Insert bolt in rifle, make sure the rifle is not loaded.

2. Insert 2mm hex wrench through trigger guard and tighten green screw (not green on actual rifle). Pull the trigger to see if the sear drops and the firing pin activates.

3. Keep tightening the green screw until the sear does not fall and the firing pin does not activate when you pull the trigger.

4. Loosen the green screw until the sear/firing pin start working properly and then set the overtravel where you want it. This screw may need some loctite on it to stay in place.

5. If you tighten the screw too far, the trigger will not function. If this happens, just loosen the screw until the trigger functions. If you loosen the screw too much, the trigger will still function but there will be excessive overtravel which you might not prefer.

D. Trigger removal

It may be necessary or desirable to remove the trigger for maintenance or cleaning.

To do this follow these steps:

1. Remove magazine, unload rifle and **remove the bolt completely from the action.**
2. Put safety selector lever in the "Safe" position.
3. Insert 5mm hex wrench through hole in bottom of trigger guard.
4. Loosen screw holding trigger onto action and remove trigger by pulling it downwards away from the action.
5. It may be necessary to loosen the grip panels as they clamp onto the trigger guard a bit, use the same 5mm hex wrench.
6. To reinstall, reverse the procedure, making sure that the bolt is removed before you try to install the trigger. Tighten trigger to approximately 50-65 in-lbs.



3.4 THE BARREL

A. Barrel break-in

1. 1 shot, clean, for 10 rounds
2. 5 shots, clean, do this 5 times
3. Clean after every 20 rnds until 100

B. Removing the barrel

The barrel on the SOTIC rifle can be removed by the end user using either a Savage barrel nut wrench or the special KRG wrench. A certified gunsmith can install a new barrel easily.

1. Remove bolt, optic, and magazine from rifle and ensure there is not a live round in the chamber
2. If you are using the KRG barrel nut wrench, you do not need to remove the action from the stock. If you use a Savage barrel nut wrench that wraps all the way around the barrel, the barreled action must be removed from the stock.
3. Place the wrench onto the barrel nut, ensuring maximum tooth engagement.

4. Attach 3/8" or 1/2" socket drive wrench to barrel nut wrench and turn the barrel nut counter-clockwise (toward ejection port) to loosen the nut a few turns.
5. When barrel nut is loosened, barrel can be turned counter-clockwise and unthreaded from action.



C. Installing the barrel

To install new barrel or re-install old barrel (to be done by certified gunsmith):

1. Apply grease or anti-seize to tenon threads on new barrel and barrel nut and thread barrel nut onto barrel with the slots in the nut facing toward the muzzle
2. Install bolt into action and lock into place
3. Put "Go" headspace gauge into chamber of barrel and thread barrel into action until it forces headspace gauge against bolt face
4. Keeping the barrel position, tighten the barrel nut against the action face using the KRG barrel nut wrench or a standard Savage barrel nut wrench.
5. Tighten barrel nut to 100 ft-lbs with torque wrench. Remember that the barrel nut wrench adds length to your torque wrench and so the proper torque value must be calculated and set on the torque wrench.
6. Check headspace, bolt should close on a "Go" gauge and not close on a "No Go" gauge, adjust headspace if necessary by loosening barrel nut, turning barrel tighter or looser, then retightening nut.

3.5 THE CHASSIS

A. Adjusting length of pull

1. Loosen the LOP thumbscrew until it stops, it does not come all the way off.



2. Push in and hold on the thumbscrew to disengage the LOP lock.



3. Move the LOP to the desired position and release pressure on the thumbscrew.

4. Tighten LOP thumbscrew.



B. Adjusting height of cheek piece

1. Loosen the thumbscrew and remove the cheek piece, then slide the o-rings toward the bottom of the riser posts and re-insert the cheekpiece.

2. Getting into position behind the rifle, place your head gently on the cheekpiece. The cheekpiece should be too high for a proper view through the scope. With the thumbscrew slightly loose, push the cheekpiece down with your head until it rests in the proper position so you have a perfect view through the scope. Tighten the thumb screw to lock the cheekpiece in that position. When you need to remove the rifle bolt from the action for cleaning, the o-rings will keep the position you selected when you re-install the cheek piece.

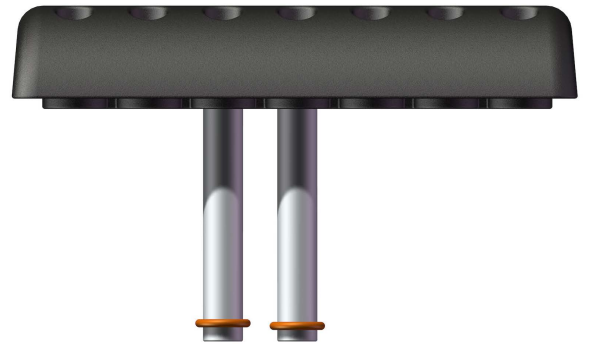

3. (Optional) You can move the cheek piece forward and backward by removing the two screws holding the cheek piece to the two cheek riser posts and then switching the holes in which the riser posts sit. (use 3mm hex wrench)

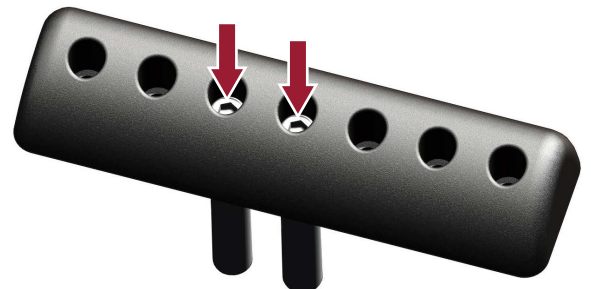

C. Adjusting height and cant of butt-pad

1. Extend out the LOP to gain access to the thumbscrew which holds the buttpad in place and loosen the thumbscrew.



D. Folding/Extending the stock

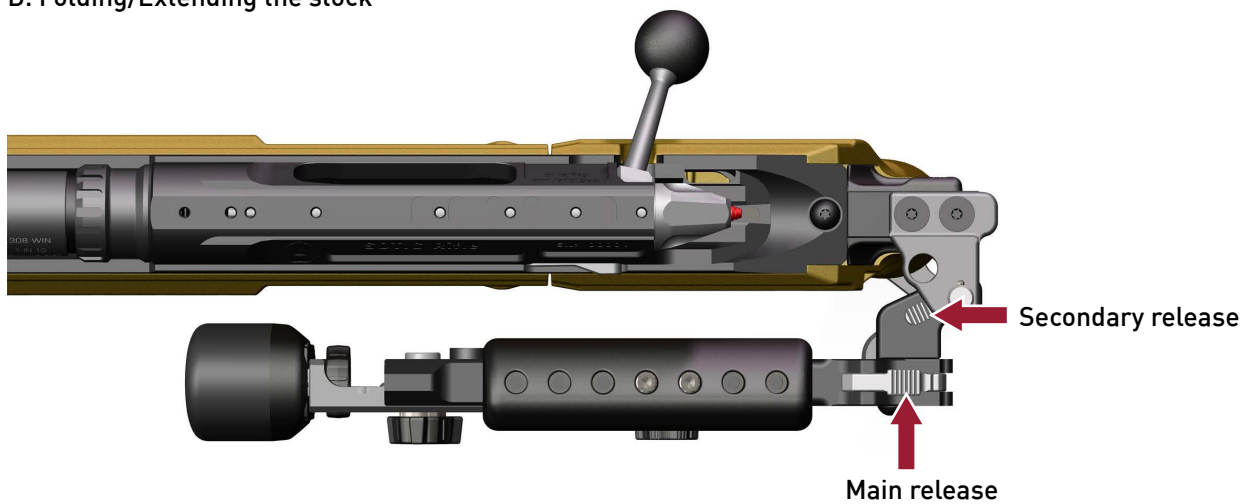

Note: There are two different latches in the folding mechanism, the main one to lock the stock in the extended or usable position and a secondary one to lock the stock in the folded position.

1. The latch mechanism to hold the buttstock in the folded position is a positive lock system. You **MUST** press the unlock button pictured above to unfold the stock. It does not release just by pulling on the buttstock.

2. Latch mechanisms were designed to be strong and reliable and if treated properly will give you thousands of folding/unfolding cycles. Do not abuse the latch mechanisms, i.e. carry a complete rifle by just the folded buttstock or open the stock from the folded position without pushing the unlock button. We recommend that when carrying in the folded position during heavy field use, strap the buttstock down with a length of nylon or route a strap from your scope cover around it to keep it from getting snagged.

4. LOADING AND UNLOADING OF THE RIFLE

4.1 LOADING

1. Ensure the rifle is pointed in a safe direction.
2. Insert a loaded magazine into the magazine well. Give it a slight tug downward to be sure it is fully seated.
3. Cycle the bolt to chamber a round.
4. The rifle is now ready to fire.

4.2 UNLOADING

1. Ensure the rifle is pointed in a safe direction.
2. Remove magazine from the rifle.
3. Open the bolt to extract the round in the chamber and be sure to check the chamber, magazine well, and bolt-face to ensure they are clear of any rounds.

5. ROUTINE CLEANING PROCEDURE

1. Ensure that the rifle is unloaded and remove the magazine and bolt.
2. In case the rifle has been used in wet conditions dry it using compressed air or let it dry in a warm / dry place without any protective cover i.e. rifle case.
3. Use a 1 piece cleaning rod equipped with a cleaning patch or nylon brush with gun oil and push it through the bore, always going from the chamber to the muzzle. It is recommended to use a bore guide when cleaning your barrel.
4. Replace cleaning tip with a bore brush soaked in bore solvent and push it through the bore until major residues are removed (approx. 10-15 times).
5. Clean the chamber with a short rod and towel or patches, a patch wrapped around the nylon brush works well for this.
6. Run a dry patch through to absorb excess bore solvent, then a lightly oiled patch if it will be some time until the rifle is used.

Other Routine Cleaning-done after getting the rifle dirty or 4 months time:

1. Clean the inside of the receiver of all dirt and residue using a towel, patches, etc.
2. Clean dirt and residue from the bolt body and bolt face and in particular the cam surface at the rear of the bolt.
3. Remove firing pin and clean off any residue that might prevent firing pin travel.
4. Remove trigger and use compressed air to clean out any dirt or debris from inside trigger.
5. Thoroughly dry the rifle if it has gotten wet with water, do not put a wet rifle in a case or safe.
6. Put a light coat of oil on the bolt and appropriate places as shown, and grease the appropriate places as shown.

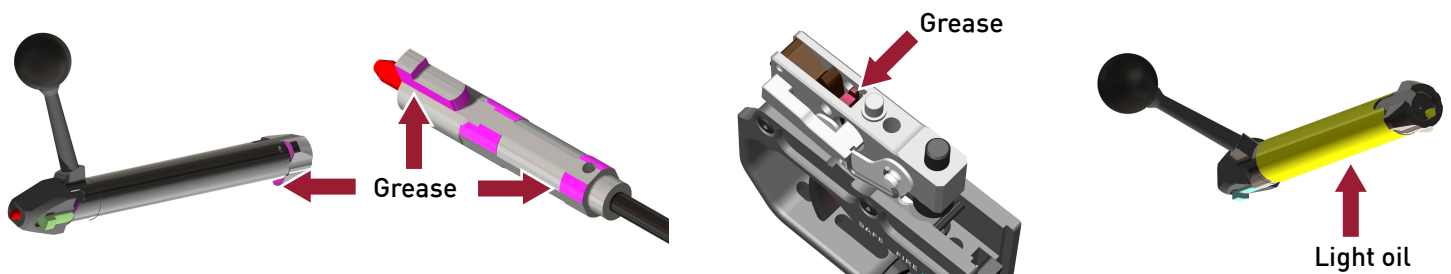

6. TECHNICAL AND SUPPORT

6.1 TORQUE SETTINGS

	IN-LB	FT-LB
Action Screws	65	
Rail Screws	15	
Trigger	55-65	
Barrel Nut		100 (Greased)

6.2 SUPPORT CONTACT INFO

Email: sotic@krg-ops.com

Phone: 720-234-1145

Website to download digital copy of manual: www.krg-ops.com